

- * High Reliability
- * High Noise Resistance
- * Wide operating voltage
- * Low current consumption
- * Harsh circumstances suitable

- * 高可靠度
- * 高抗干擾力
- * 廣泛工作電壓範圍
- * 低耗電高效能
- * 適用於惡劣環境不怕粉塵



Guiding of model Incremental type 型號索引

Ex **MES - 2500 D - E - 8Φ - M12**
 1 2 3 4 5 6

1	Product (產品代號) : 「MES」 = 40Φ Magnetic Incremental Encoder 「MET」 = 50Φ Magnetic Incremental Encoder 「MEN」 = 30Φ Magnetic Incremental Encoder 「MEP」 = Plate type Magnetic Incremental Encoder	4	Structure strength MET type only 「E」 : Heavy duty type 「Non」 : Standard type
		5	Shaft diameter (轉軸外徑) : 「Non」 = 6.0 mm 「8Φ」 = 8.0 mm 「H8」 = Hole shaft 8.0 mm 「H10」 = Hole shaft 10.0 mm
2	Resolution (解析度) : 4PPR ~ 4096 PPR 「05」 = 5 PPR 「500」 = 500 PPR 「2500」 = 2500 PPR	6	Option (附加功能) : 「Non」 = Cable lead wire 「PG」 = M12 Lead wire 「M12」 = M12 connection MET type only 「ZL」 = Z Phase low level output 「MW」 = Meter wheel type
3	Output method (輸出方式) : 「D」 = Line driver 「N」 = NPN 「P」 = PNP		
Note	1> Pulse per Revolution (PPR) 5,10,20,30,40,50,60,100,120,150,180,200,250,300,360,400,500,512,600,720,800,1000,1024,1200,1500,1800,2000,2048,2500 2> It is accepted to manufacture for special resolution. 可接受訂製非規格的解析度。		

Output circuit / 輸出回路

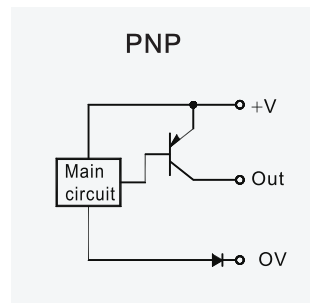
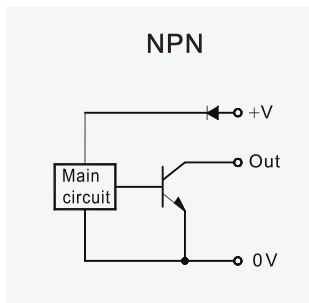
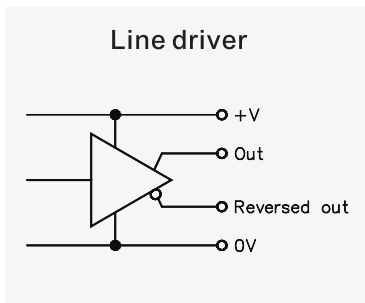

Note

「Z phase」 standard output level is 「High level」, if require 「Low level」 output, Please order 「ZL」 type.
 標準「Z phase」輸出準位是「高準位」, 如果要「低準位」輸出請訂「ZL」形式。

Electrical Specification / 電氣規格

Output model	輸出型式	NPN	PNP	Line Driver
Operating voltage	工作電壓	5~30VDC	5~30VDC	5VDC ±10%
Output method	輸出方式	NPN	PNP	Line driver IC
Response frequency	響應頻率	30K ~120K Hz		
Current consumption	耗電流	40 mA max.		
Ripple of power	電源漣波	10 peak to peak		
Output current	輸出電流	100mA max.		20mA max.
Protection circuit	保護回路	Short circuit & polarity reversed		Polarity reversed
Voltage drop	輸出壓降	0.6V max.		
Residual voltage	殘餘電壓	0.1V max.		
Leakage current	洩漏電流	0.1mA max.		
Noise resistance	抗干擾	2kv / 1 μs		
Dielectric strength	電介強度	2.5kv / 1 minute min.		
Insulation strength	絕緣強度	100 MΩ / 500vdc		
Approval	安規	CE / RoHS		

Mechanical Data & Environment Data / 環境規格 & 機械規格

Type	Standard type			Heavy duty
Outline	30Φ	40Φ	50Φ	50Φ
Model	MEN	MES	MET	MET-□□□-E
Starting torque	20 gf-cm max.	30 gf-cm max	30 gf-cm max	260 gf-cm max
Shaft moment of inertial	6 g-cm ² max	8 g-cm ² max.	8 g-cm ² max	68 g-cm ² max
Shaft loading(Radial)	1kg max.	2 kg max.	2 kg max.	10 kg max.
Shaft loading(Axial)	0.5 kg max.	1 kg max.	1 kg max.	5 kg max.
Rotational speed max.	6000 RPM			
Housing material	Intensive PPS			
Shaft material	SUS-316			
Vibration resistance	10 ~ 55 Hz / 1.5 mm ; 2Hr/ X.Y.Z direction each			
Shock resistance	490m/s ² with 11ms in X.Y.Z direction 3times each			
Operating circumstance	-25°C ~ +70°C ; 85%RH max.			
Protection class	IP-64			

Connections / 接線圖

NPN/PNP		
Connector No.	Color	Description
# 1	Brown	+ V 1
# 3	Blue	0 V 3
# 4	Black	Phase A 4
# 2	White	Phase B 2
# 5	Yellow	Phase Z 5

Line driver (差動式)			
Color	Description	Color	Description
Brown	+ V (1)	Blue	0 V(3)
Black	Phase A (4)	Blue/Red	Phase A(9)
White	Phase B (2)	White/Red	Phase B(10)
Yellow	Phase Z (5)	Yellow/Red	Phase Z(11)

Output timing chart / 輸出時序圖

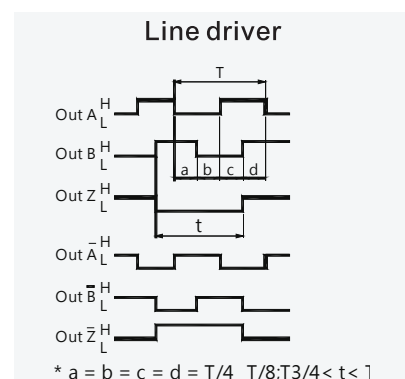
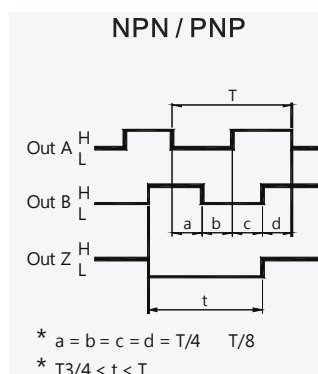

- * High Reliability
- * High Noise Resistance
- * Wide operating voltage
- * Electronic zero point settable
- * Harsh circumstances suitable
- * Several output code optional

- * 高可靠度
- * 高抗干擾力
- * 廣泛工作電壓範圍
- * 電氣零點可設定
- * 適用於惡劣環境不怕粉塵
- * 多種輸出碼可選擇



Guiding of model Absolute type 型號索引

Ex **MAT - 1024 P - BCD - E - 8Φ - M12**

1 2 3 4 5 6 7

1	Product (產品代號) : 「MAT」 = 5 Φ Magnetic Absolute Encoder 「MAP」 = Plate type Magnetic Absolute Encoder	5	Structure strength MET type only 「E」 : Heavy duty type 「Non」 : Standard type
2	Resolution (解析度) : 4PPR ~ 1024PPR 「256」 = 256 PPR (8 bit) 「360」 = 360 PPR (9 bit) 「1024」 = 1024 PPR (10 bit)	6	Shaft diameter (轉軸外徑) : 「Non」 = 6.0 mm 「8Φ」 = 8.0 mm
3	Output method (輸出方式) : 「N」 = NPN 「P」 = PNP	7	Connection method (出線方式) : 「Non」 = Lead wire 「PG」 = M12 Lead wire 「M12」 = M12 connection
4	Output code (輸出碼) : 「GC」 = Gray code 「Non」 = Binary code 「BCD」 = BCD code	Note	Pulse per Revolution (PPR) : 4 / 6 / 8 / 12 / 16 / 24 / 32 / 64 / 128 / 256 360 / 512 / 720 / 1024
Note	It is accepted to manufacture for special resolution. 可接受訂製非規格的解析度。		

Output circuit / 輸出回路

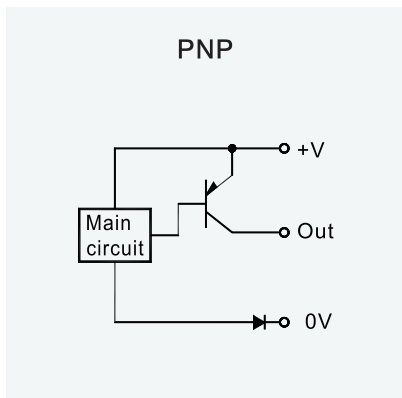
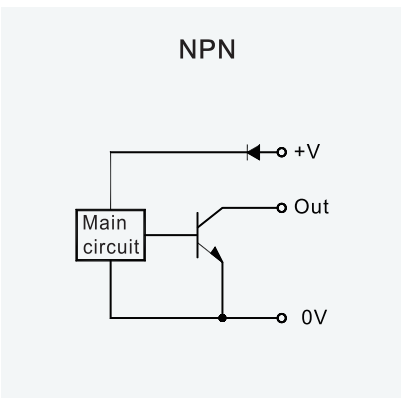

Input circuit / 輸入回路

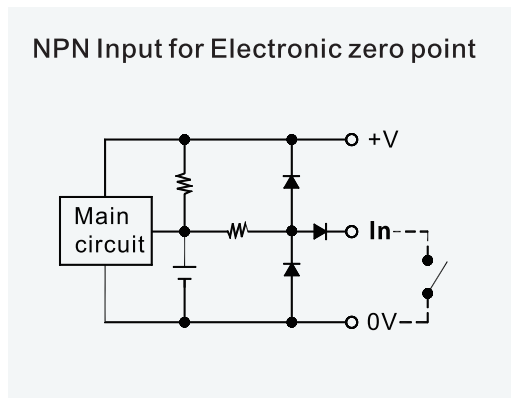

Electrical Specification / 電氣規格

Output method	輸出方式	NPN	PNP
Operating voltage	工作電壓	5 ~ 30VDC	
Output code	輸出碼	Gray code, Binary code or BCD code	
Response frequency	響應頻率	20 KHz min.	
Current consumption	耗電流	60 mA max.	
Ripple of power	電源漣波	10 peak to peak	
Output current	輸出電流	100mA max.	
Protection circuit	保護回路	Short circuit & polarity reversed	
Voltage drop	輸出壓降	0.6V max.	
Residual voltage	殘餘電壓	0.1V max.	
Leakage current	洩漏電流	0.1mA max.	
Noise resistance	抗干擾	2kv / 1 μ s	
Dielectric strength	電介強度	2.5kv / 1 minute min.	
Insulation strength	絕緣強度	100 M Ω / 500vdc	
Approval	安規	CE / RoHS	

Mechanical Data / 機械規格

Type	Standard type	Heavy duty
Outline	50 Φ	50 Φ
Model	MAT-□□□	MAT-□□□-E
Starting torque	起動力矩	30 gf-cm max
Shaft moment of inertial	慣性力矩	8 g- cm ² max
Shaft loading(Radial)	轉軸負載	2 kg max.
Shaft loading(Axial)	轉軸負載	1 kg max.
Rotational speed max.	最大轉速	6000 RPM
Housing material	外殼材質	Intensive PPS
Shaft material	轉軸材質	SUS-316
Operating circumstance	工作環境	-25 $^{\circ}$ C ~ +70 $^{\circ}$ C ; 85%RH max.
Vibration resistance	抗振動	10 ~ 55 Hz / 1.5 mm ; 2Hr/ X.Y.Z direction each
Shock resistance	抗沖擊	490m/s ² with 11ms in X.Y.Z direction 3times each
Protection class	保護等級	IP-64

Connections / 接線圖

Connector No.	Wire color	Description	Connector No.	Wire color	Description
# 1	Brown	+ V	# 8	Black/Red	2 ⁵
# 3	Blue	0 V	# 9	Grey/Red	2 ⁶ (CLK1)
# 4	Black	2 ⁰	# 10	White/Red	2 ⁷ (CLK2)
# 2	White	2 ¹	# 11	Yellow/Red	2 ⁸ (Parity)
# 5	Yellow	2 ²	# 12	Green/Red	2 ⁹ or Zero in
# 6	Grey	2 ³	Non	Orange	Zero in
# 7	Green	2 ⁴			

■ Electrical Specification / 電氣規格

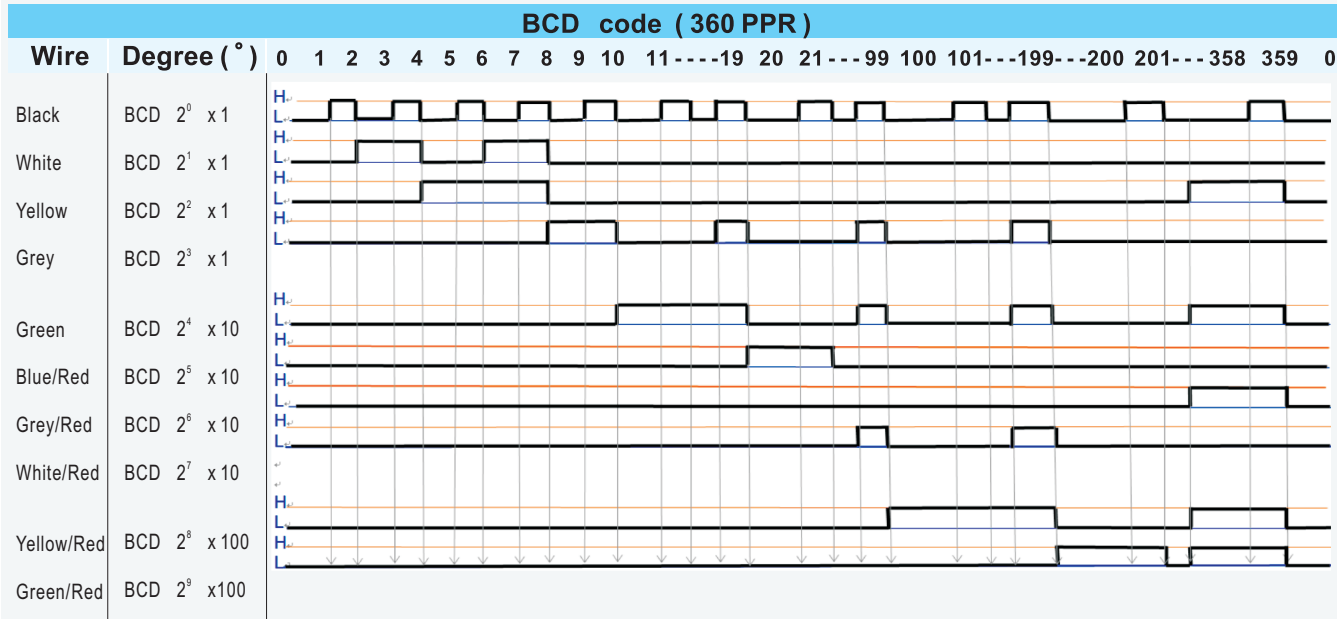
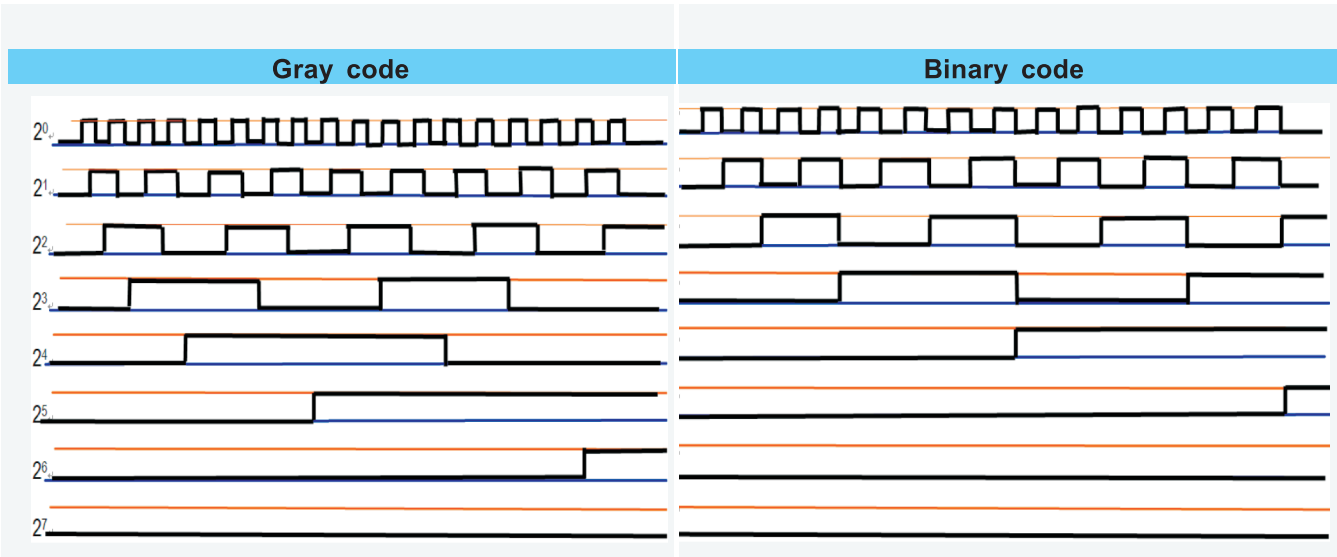

■ How to set the Zero point of Absolute Encoder

Please open the wire of Zero in with the 0V after connecting while in power on status. Note that Zero in must be opened in operating status.

「送電中」請將「Zero in 和「0V 接觸後即可將絕對值式譯碼器歸零。
請注意運轉操作中「Zero in 不可和「0V 接在一起！

■ How to set the Direction of Absolute Encoder CW/CCW setting

Please connect the wire of Zero in with the 0V before turning power on . then open the wire of Zero in with the 0V after power on over 10 seconds. direction of CW/CCW will be changed.

Note that Zero in must be opened in operating status.

可切換「CW/CCW 方向。請注意運轉操作中「Zero in 不可和「0V 接在一起！

「送電前」請將「Zero in 和「0V 接在一起，送電10秒以上再拆開「Zero in 和「0V 。

Coupling Specification / 聯軸器規格

Model	型號	G2J-66	G2J-68	G2J-88
Diameter d1	軸徑	6.0mm	6.0mm	8.0mm
Diameter d2	軸徑	6.0mm	8.0mm	8.0mm
Outline diameter	外徑	18.0mm		
Outline length	長度	23.0mm		
Set screw	固定螺絲	M3 x 4		
Material	材質	Intensive Polyimide		

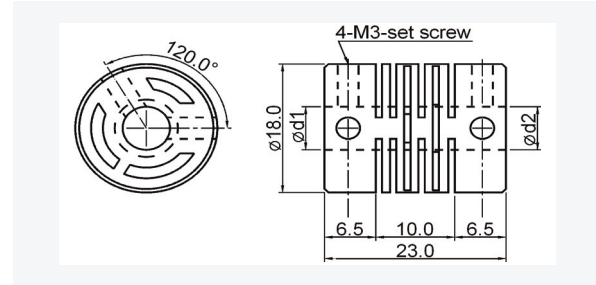

Outline dimension / 外形圖

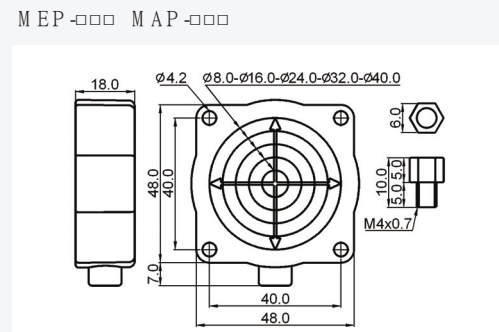
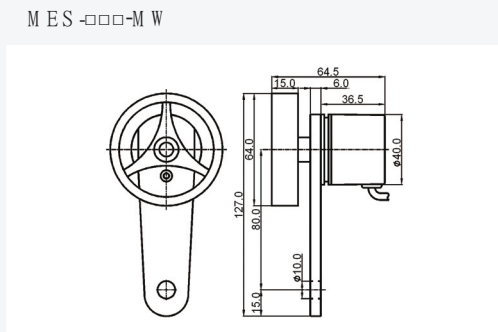
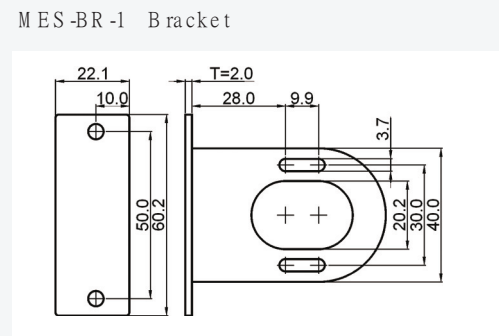
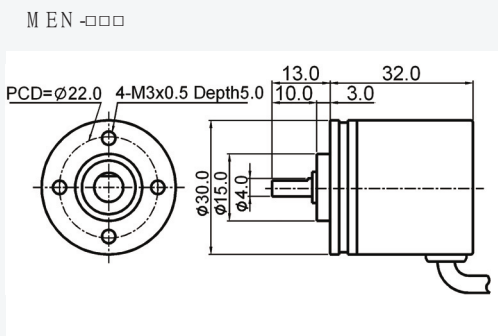
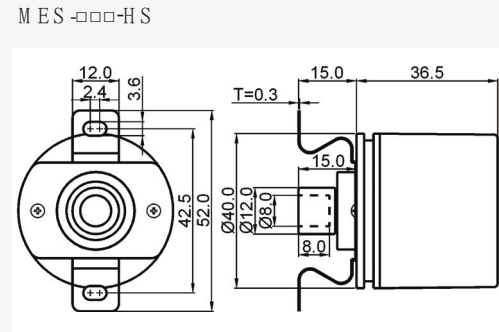
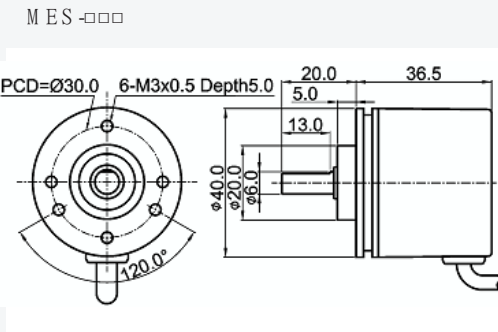
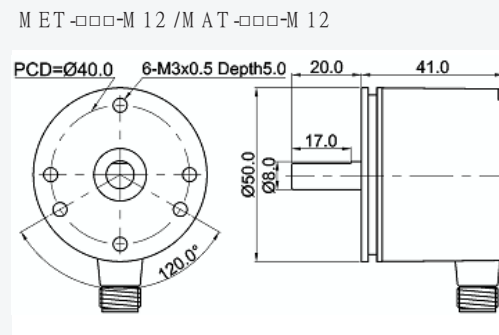
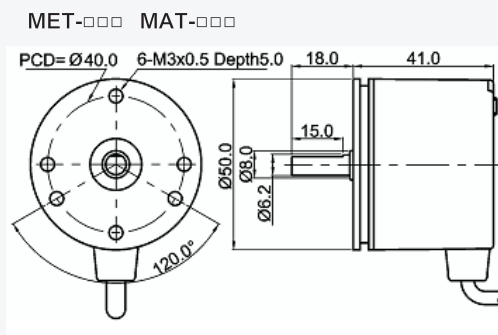

※ 以使用者角度設計

『實用耐用的電控產品』

※ 以量產標準化製造

『世界標準的電控產品』

※ 以滿足客戶需求追求

『企業永續經營』

※ On user's position, to develop
more 「Performance & Reliable controls」

※ By mass-quantity producing, To produce
「World standard controls」

※ By satisfying customer's requirements,
To manage company foreverly.

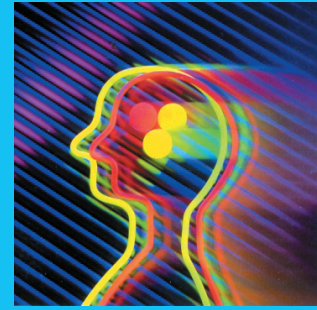

Think Controls

FOTEK

陽明電機股份有限公司
FOTEK CONTROLS CO., LTD.

Specification may be modified without notice in advance (2012/11/26)

規格變更恕不事先通知